



TxIsoLoop-1

TxIsoLoop-2

Loop-Powered Isolators

USER GUIDE – V1.0x I



1.	SAFETY ALERTS	3
2.	INTRODUCTION.....	4
3.	SPECIFICATIONS	5
4.	ELECTRICAL INSTALLATION	6
4.1	ELECTRICAL CONNECTIONS	7
4.2	TXISOLOOP-2 – SIGNAL SPLITTER FUNCTION	8
4.2.1	ACTIVE CURRENT SIGNAL.....	8
4.2.2	PASSIVE CURRENT SIGNAL	8
4.3	INSTALLATION RECOMMENDATIONS	8
5.	MECHANICAL INSTALLATION	9
6.	WARRANTY.....	10

1. SAFETY ALERTS

The symbols below are used in the device and throughout this manual to draw the user's attention to valuable information related to device safety and use.

		
CAUTION Read the manual fully before installing and operating the device.	CAUTION OR HAZARD Risk of electric shock.	ATTENTION Material sensitive to static charge. Check precautions before handling.

All safety recommendations appearing in this manual must be followed to ensure personal safety and prevent damage to the instrument or system. If the instrument is used in a manner other than that specified in this manual, the device's safety protections may not be effective.

2. INTRODUCTION

TxIsoLoop-1 and **TxIsoLoop-2** galvanic isolators are devices used for electrical isolation of 0(4)-20 mA current signals. Its purpose is to avoid measurement errors typically found in installations that have problems with electrical potential difference and ground loops

These isolators do NOT require an electrical power supply. The energy obtained by passing the electric current through the insulator input actively generates the output current.

Features:

- Galvanic isolation between input and output.
- Models with one or two input/output channels.
- The device does not require a power supply.
- High accuracy.

3. SPECIFICATIONS

FEATURES	TXISOLOOP
Input signal	0(4) to 20 mA (Check minimum current for proper operation)
Voltage drop - Input/output without protection (Vdrop)	< 3 Vdc
Voltage drop - Input/output with protection (Vdrop)	< 5 Vdc
Output signal	0(4) to 20 mA
Max. load (RL)	1450 R
Total accuracy	<ul style="list-style-type: none"> • 0.2 % @ 0 to 60 °C / RL = 250 R • 0.3 % @ -20 to 75 °C / RL = 250 R
Minimum operating current	> 0.1 mA
Maximum input current	< 40 mA
Response time	2 ms @ RL= 250 R
Current limit	31 mA
Electrical isolation	<ul style="list-style-type: none"> • 3000 Vac / 10 seconds • 240 Vac continuous
EMC	EN 61326-1 (without performance degradation)
Work environment	<ul style="list-style-type: none"> • Temperature: -20 to 75 °C • Relative humidity: 20 to 90 %
Housing	ABS (60 %) + PC (40 %)
Protection index	IP40
Wire gauge for connections	0.14 a 1.5 mm ²
Recommended torque	0.8 Nm
Terminal enclosure	Polyamide

Table 1 Technical specifications

4. ELECTRICAL INSTALLATION

To ensure perfect operation of the **TxIsoLoop** isolator, the circuit where the isolator input is connected must provide a minimum electrical voltage (V_1).

You can supply the electrical voltage in two ways:

1. The device that generates the current signal is of the active type (source), where it provides the necessary electrical voltage itself.

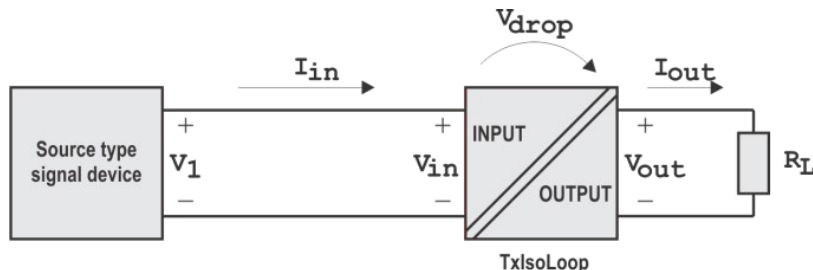

Figure 1 TxIsoLoop connections with source type device

With type source devices (transmitters, controllers, etc.), this voltage is provided by the device itself.

The minimum voltage value to be supplied by the generator can be calculated using the formula below:

$$V_1 = V_{in} \quad \text{Where: } V_{in} = V_{drop} + (I_{out(max)} \times R_L)$$

$$I_{in} = I_{out}$$

2. With sink type devices (2-wire transmitters), the energy is provided by an external power supply in series in the loop, as shown in Figure 2.

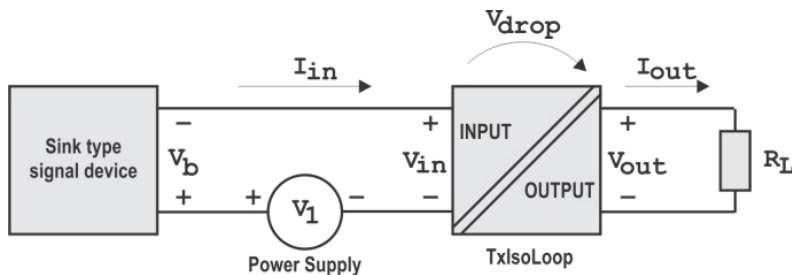

Figure 2 Connections on the TxIsoLoop with sink type devices

In this option, the inserted source must provide enough voltage to meet the needs of the current generating device (generator, transmitter, controller, etc.) and the isolator.

The minimum voltage value to be supplied by the power supply can be calculated using the formula below:

$$V_1 = V_b + V_{in}$$

Where: V_1 = Voltage from the source inserted into the circuit

V_b = Minimum voltage of the generator

$$V_{in} = V_{drop} + (I_{out(max)} \times R_L)$$

$$I_{in} = I_{out}$$

4.1 ELECTRICAL CONNECTIONS

To configure **TxIsoLoop-1**, use the following wiring diagram:

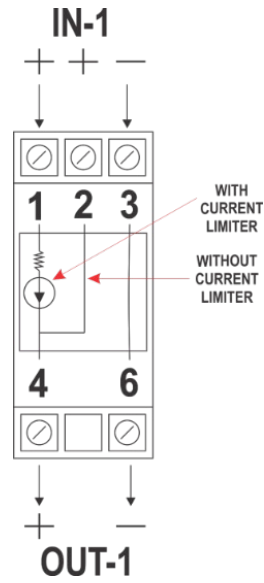

Figure 3 TxIsoLoop-1 Connections

To configure **TxIsoLoop-2**, use the following wiring diagram:

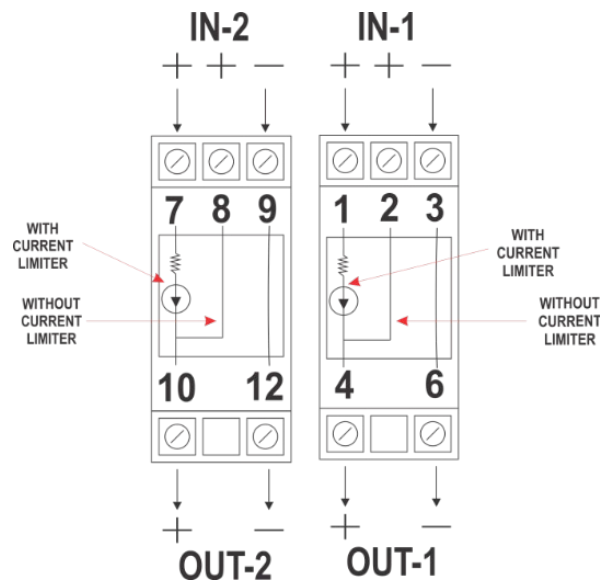

Figure 4 TxIsoLoop-2 Connections

4.2 TXISOLOOP-2 – SIGNAL SPLITTER FUNCTION

If needed, TxIsoLoop-2 can be used as a 4-20 mA signal splitter, as shown in the figures below:

4.2.1 ACTIVE CURRENT SIGNAL

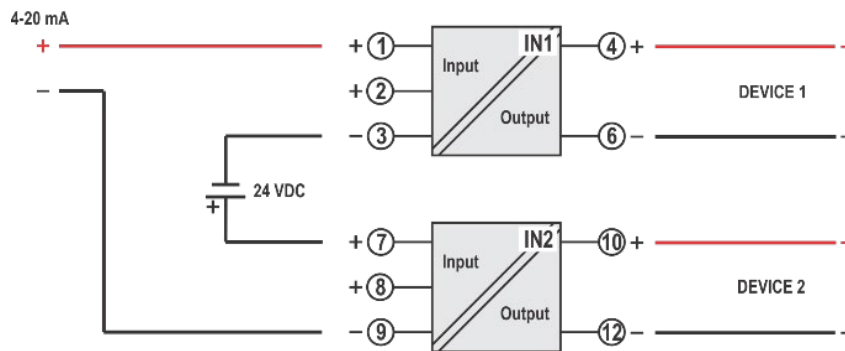

Figure 5 Active current signal

4.2.2 PASSIVE CURRENT SIGNAL

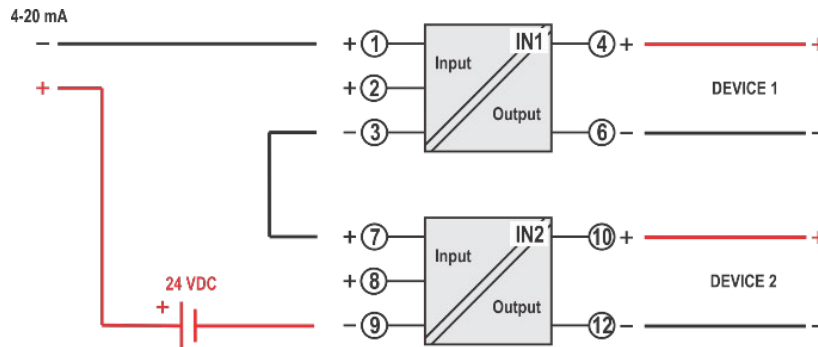

Figure 6 Passive current signal



To duplicate the signal, the two outputs of the device must be connected to a load.

4.3 INSTALLATION RECOMMENDATIONS

- Input signal conductors must run through the plant separately from the supply and output conductors. If possible, in grounded conduits.
- The power supply for the electronic instruments must come from a proper instrumentation network.
- In control applications, it is essential to consider what can happen when any part of the system fails.
- It is recommended to use RC FILTERS (noise suppressors) at contactor coils, solenoids, etc.

5. MECHANICAL INSTALLATION

The transmitter is intended for a 35 mm DIN rail mounting.

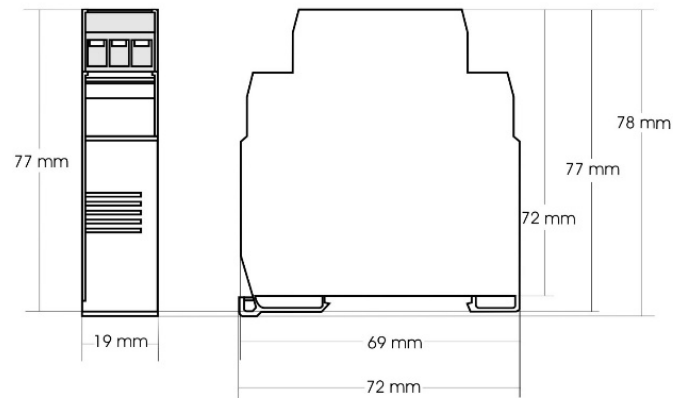

Figure 7 Isolator dimensions

6. WARRANTY

Warranty conditions are available on our website www.novusautomation.com/warranty.