



CONTROLLER N1040T

TIME AND TEMPERATURE CONTROLLER

USER GUIDE V2.1x 0



NOVUS
We Measure, We Control, We Record



1.	SAFETY ALERTS.....	3
2.	INSTALLATION / CONNECTIONS.....	4
2.1	ELECTRICAL CONNECTIONS.....	4
2.2	INSTALLATION RECOMMENDATIONS.....	4
3.	FEATURES.....	5
3.1	SIGNAL INPUT.....	5
3.2	DIGITAL INPUT (DIG IN).....	5
3.3	OUTPUTS.....	5
3.4	TEMPERATURE CONTROL OUTPUT.....	5
3.5	ALARM OUTPUT.....	5
3.6	ALARM INITIAL BLOCK.....	6
3.7	OFFSET.....	6
3.8	LOOP BREAK DETECTION FUNCTION.....	6
3.9	SAFE OUTPUT FUNCTION DURING SENSOR FAILURE.....	6
3.10	USB INTERFACE.....	6
4.	TIMERS.....	8
4.1	T1 TIMER.....	8
4.1.1	T1 TIMER – STARTUP MODES.....	8
4.1.2	T1 TIMER – OPERATION MODES.....	8
4.2	T2 TIMER.....	8
4.3	TIMING DIRECTION.....	8
4.4	BEHAVIOR OF THE TEMPERATURE CONTROL AT THE END OF THE TIMER.....	9
4.5	TIMER TIME BASE.....	9
5.	OPERATION.....	10
5.1	STARTUP.....	10
6.	PARAMETER DESCRIPTION.....	11
6.1	OPERATION CYCLE.....	11
6.2	TUNING CYCLE.....	11
6.3	TIMER CYCLE.....	12
6.4	ALARM CYCLE.....	12
6.5	INPUT CYCLE.....	13
6.6	CALIBRATION CYCLE.....	13
7.	CONFIGURATION PROTECTION.....	15
7.1	PASSWORD.....	15
7.2	PASSWORD PROTECTION.....	15
7.3	MASTER PASSWORD.....	15
8.	SETTING THE PID PARAMETERS.....	16
9.	MAINTENANCE.....	17
9.1	PROBLEMS WITH THE CONTROLLER.....	17
9.2	INPUT CALIBRATION.....	17
10.	SPECIFICATIONS.....	18
11.	IDENTIFICATION.....	19
12.	WARRANTY.....	20

1. SAFETY ALERTS

The following symbols are used on the equipment and throughout this manual to draw the user's attention to important information related to the safety and use of the equipment.

	
<p>CAUTION: Read the manual completely before installing and operating the equipment.</p>	<p>CAUTION OR HAZARD: Risk of electric shock.</p>

All safety recommendations appearing in this manual must be followed to ensure personal safety and prevent damage to the instrument or system. If the instrument is used in a manner other than that specified in this manual, the device safety protections may not be effective.

2. INSTALLATION / CONNECTIONS

The controller should be attached to a panel, following the sequence of steps below:

- Make a panel cutout, as shown in the [SPECIFICATIONS](#) section.
- Remove the mounting clamp from the controller.
- Insert the controller into the panel cutout.
- Reattach the mounting clamp on the controller, pressing until a firm hold is obtained.

2.1 ELECTRICAL CONNECTIONS

The layout of the features on the back panel of the controller is shown in **Figure 1**:

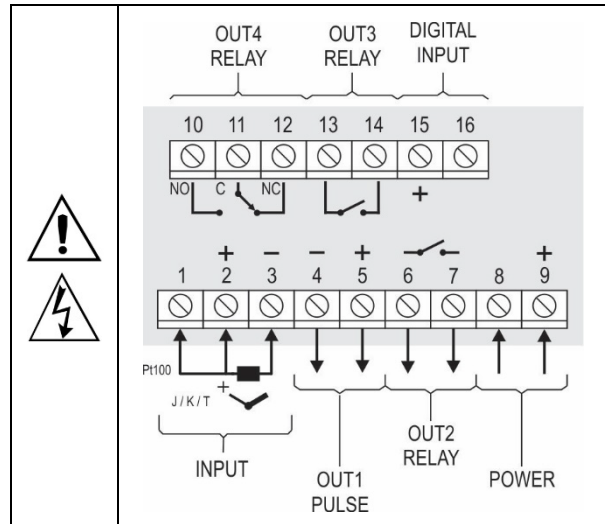

Figure 1 – Electrical connections

2.2 INSTALLATION RECOMMENDATIONS

- Input signal conductors must run through the plant separately from the supply and output conductors. If possible, in grounded conduits.
- The power supply for the electronic instruments must come from a proper instrumentation network.
- It is essential to use RC FILTERS (noise suppressors) at contactor coils, solenoids, etc.
- In control applications, it is essential to consider what can happen when any part of the system fails. The internal devices of the equipment do not guarantee full protection.

3. FEATURES

3.1 SIGNAL INPUT

The input type to be used must be defined during equipment configuration.

Table 1 shows the available input options:

TYPE	CODE	MEASUREMENT RANGE
Thermocouple J	tc J	Range: -110 to 950 °C (-166 to 1742 °F)
Thermocouple K	tc K	Range: -150 to 1370 °C (-238 to 2498 °F)
Thermocouple T	tc T	Range: -160 to 400 °C (-256 to 752 °F)
Pt100	Pt	Range: -200 to 850 °C (-328 to 1562 °F)

Table 1 – Input type

3.2 DIGITAL INPUT (DIG IN)

Available at terminals 15 and 16 on the back panel. It recognizes the closure of Dry Contact switches.

The **A3** flag indicates the Digital Input condition:

- On = DI enabled (closed).
- Off = DI disabled (open).

3.3 OUTPUTS

The controller has 2 or 4 output channels, according to the model ordered. These channels must be configured to operate as **Control Output**, **T1 Timer Output**, **T2 Timer Output**, or **Alarm 4 Output**.

- OUTPUT 1** Voltage pulse output type, 5 Vdc / 50 mA max. Available at terminals 4 and 5.
- OUTPUT 2** SPST-NO Relay. Available at terminals 6 and 7.
- OUTPUT 3** SPST-NO Relay. Available at terminals 13 and 14.
- OUTPUT 4** SPDT Relay. Available at terminals 10, 11, and 12.

3.4 TEMPERATURE CONTROL OUTPUT

The process control output can operate in the following modes:

- 1) ON/OFF Mode or
- 2) PID Mode.

To operate in ON/OFF Mode, you must set the **Pb** parameter to **0.0**. The values of the PID parameters can be set automatically with the Auto-tuning function (**Autun**).

3.5 ALARM OUTPUT

The controller has an alarm, which can be directed to any output channel and can operate with one of the functions described in Table 2:

oFF	Alarm off.	
Lo	Absolute Minimum Value Alarm. It triggers when the PV (temperature) value is below the value set by the Alarm Setpoint (SPA4).	
Hi	Absolute Maximum Value Alarm. It triggers when the PV value is above the value set by the Alarm Setpoint.	
dIF	Differential Value Alarm. In this function, the SPR4 parameter represents a difference between PV and control SP.	
		<div style="display: flex; justify-content: space-around;"> <div style="text-align: center;"> <p>SP - SPA4 SP SP + SPA4</p> <p>Positive SPA4</p> </div> <div style="text-align: center;"> <p>SV + SPA4 SP SV - SPA4</p> <p>Negative SPA4</p> </div> </div>
dIFL	Minimum Differential Value Alarm. It triggers when the PV value is below the point set by SP-SPA4 (using alarm 1 as an example).	
		<div style="display: flex; justify-content: space-around;"> <div style="text-align: center;"> <p>SP - SPA4 SP</p> <p>Positive SPA4</p> </div> <div style="text-align: center;"> <p>SP SP - SPA4</p> <p>Negative SPA4</p> </div> </div>

d IFFH	Maximum Differential Value Alarm. It triggers when the PV value is above the point set by SP+SPA4.	
	Positive SPA4	Negative SPA4
IErr	Open Sensor Alarms (Sensor Break Alarm). It operates when the input presents problems such as a broken sensor, poorly connected sensor, etc.	

Table 2 – Alarm functions

Important note: Alarms configured with functions **H I**, **d IFF**, and **d IFFH** will also trigger the related output when the controller identifies and signals a sensor failure. A relay type output configured to act as a Maximum Alarm (**H I**), for example, will act when the SPAL value is exceeded and when the sensor connected to the controller input is broken.

3.6 ALARM INITIAL BLOCK

The Initial Block feature inhibits the alarm from being activated if an alarm condition exists in the process when the controller goes into operation. The alarm will only be enabled after the process has passed a non-alarm condition.

This function is useful, for example, at the beginning of the process control operation. At this point, the PV value is still far from the value set with SP. Thus, alarm situations are expected and often their signaling is unwanted.

The Initial Block is not valid for the **IErr** function (Open Sensor).

3.7 OFFSET

Feature that allows you to make small adjustments to the PV indication. It allows you to correct measurement errors that appear, for example, when replacing a temperature sensor.

3.8 LOOP BREAK DETECTION FUNCTION

The **Lbdt** parameter sets a maximum time interval, in minutes, for PV to react to the command from the control output. If there is not a minimal and proper reaction throughout this interval, the controller will signal the occurrence of a LBD event on its display. This indicates problems in the control loop.

If you set the **Lbdt** parameter to 0 (zero), this function is disabled.

This function allows you to detect problems in the installation, such as a bad actuator or a failure in the power supply process to the load.

3.9 SAFE OUTPUT FUNCTION DURING SENSOR FAILURE

Function that puts the control output into a safe condition for the process when identifying an error in the sensor input.

When identifying a sensor failure, the controller will set the percentage value (set in **IEou** parameter) for the control output. The controller will remain in this condition until the sensor failure disappears.

When in **ON/OFF Mode**, the values for **IEou** are only 0 and 100 %. When in **PID Mode**, any values between 0 and 100 % are accepted.

3.10 USB INTERFACE

The USB interface is used to CONFIGURE, MONITOR, or UPDATE the FIRMWARE. To do this, you must use **QuickTune** software, which offers features to create, view, save, and open configurations from the device or from files on your computer.

The feature to save and open configurations in files allows you to transfer configurations between devices and create backups.

For specific models, **QuickTune** allows you to upgrade the firmware (internal software) of the controller via USB interface.

To MONITOR, you can use any supervisory (SCADA) or laboratory software that supports Modbus RTU communication over a serial communication port.

When connected to the USB interface of a computer, the controller will be recognized as a conventional serial port (COM x).

You should use **QuickTune** software or consult the Device Manager in the Windows Control Panel to identify the COM port assigned to the device.

Refer to the Modbus memory mapping in the device communication manual and the supervisory software documentation.

To use the USB communication, follow the steps below:

1. Download **QuickTune** software, free of charge, from our website and install it on the computer to be used. The USB drivers required for the operation of the communication will be installed with the software.
2. Connect the USB cable between the device and the computer. The controller does not need to be powered. The USB interface will provide enough power for the communication to operate (other device functions may not operate).
3. Run **QuickTune**, configure the communication, and start the device recognition.



The USB interface IS NOT ISOLATED from the signal input (INPUT) and possible digital inputs and outputs of the controller. Its purpose is temporary use during CONFIGURATION and MONITORING periods.
For the safety of people and equipment, it should only be used when the equipment is fully disconnected from the input/output signals.
The USB interface can be used in any other situation, but it requires careful consideration by the people performing the installation.
For MONITORING over long periods and with the inputs and outputs connected, it is recommended to use the RS485

	interface, available or optional in most of our devices.
--	--

4. TIMERS

The controller has 2 timers, which can operate independently of the temperature control.

4.1 T1 TIMER

T1 is the main timer. It has several features that provide different modes of operation.

4.1.1 T1 TIMER – STARTUP MODES

T1 Timer has 4 trigger modes:

MODE	DESCRIPTION
RUN	Allows you to start time counting when activating control (run = YES).
SP	Allows you to start time counting when the PV value reaches the SP value set for the process.
F	Allows you to start time counting by using the F key. Once the timing has started, pressing the F key again will interrupt the process. To start a new cycle, press the F key again.
DI	Allows you to start time counting via Digital Input. When you trigger the DI (close contact), the time counting will start. If the DI is disabled (open contact) before the end of the timer, it will be interrupted. Returning to DI will start a new cycle.

Table 3 – T1 Timer

Note: If you manually set the **run** parameter to NO (control disabled), the triggering options via **F** key and DI will not allow you to re-enable control (**run = YES**).

4.1.2 T1 TIMER – OPERATION MODES

T1 Timer has 3 operation modes:

MODE	DESCRIPTION
oFF	T1 output turns off at the end of T1. In this mode, T1 output turns on at the beginning of T1 and turns off at the end of T1. The A1 flag turns on at the beginning of the timer and flashes after the end of the T1 interval.
on	T1 output turns on at the end of T1. When T1 timer starts, the T1 output remains off. At the end of the timer, T1 output is turned on and will remain in this condition until a new cycle starts. The A1 flag flashes during the timing of T1. After T1, it turns on permanently, signaling that the output is still on.
onH	T1 output remains on at the end of T1. The T1 output is switched on at the beginning of T1 timer and remains in this condition even at the end of the timing. The A1 flag turns on during the timing of T1. After T1, it starts flashing, signaling that the output is still on.

Table 4 – T2 Timer

The operation modes define the behavior of the outputs linked to the timer.

You can link to any available output: OUT1, OUT2, OUT3, or OUT4.

The A1 flag indicates the current stage of the timer.

4.2 T2 TIMER

Secondary timer. It starts its timing at the end of T1. It can also be linked to any available output on the controller. The linked output always turns on at the beginning of T2 and turns off at the end.

The A2 flag indicates the condition of timing T2:

T2 in progress → A2 on.

T2 not started or already finished → A2 off.

4.3 TIMING DIRECTION

The time counting for the timers can occur in 2 modes:

- 1) Increasing Mode or
- 2) Decreasing Mode.

In **Increasing Mode** (UP), counting starts at 0 and goes up to the programmed time interval (T1, T2)

In **Decreasing Mode** (DOWN), it starts at the programmed time value and goes down to 0.

4.4 BEHAVIOR OF THE TEMPERATURE CONTROL AT THE END OF THE TIMER

During the timing intervals of **T1** and **T2**, the temperature control has normal operation.

The output defined as Temperature Control acts to bring the PV value to the value set in SP. However, at the end of the **T1 + T2** interval, it is possible to configure the controller to disable temperature control, setting the **run** parameter to **no**.

See **tEED** Parameter (Timer Cycle).

4.5 TIMER TIME BASE

The **tBAS** parameter (Timer Cycle) allows you to set the time base to be used. The options are:

SEc MM:SS. The time intervals **T1** and **T2** are shown in minutes and seconds.

in HH:MM. The time intervals **T1** and **T2** are shown in hours and minutes.

5. OPERATION

The front panel of the controller can be seen in **Figure 2**:

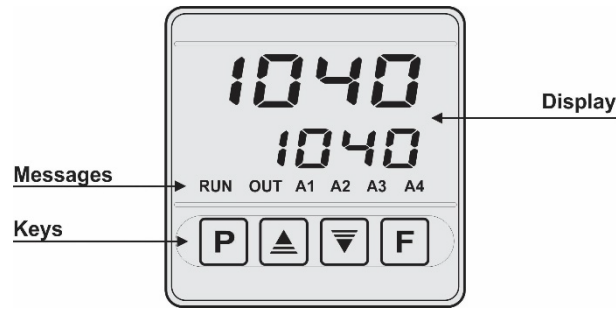

Figure 2 – Front panel identification

Display: Displays the measured variable, configuration parameter symbols, and their respective values/conditions.

TUNE flag: Remains on while the controller is in the tuning process.

RUN flag: Indicates that the controller is in operation.

OUT flag: Indicates the status of the temperature control output.

A1 flag: Indicates the status of the output linked to T1.

A2 flag: Indicates the status of the output linked to T2.

A3 flag: Indicates the Digital Input condition.

A4 flag: Indicates the Alarm 4 condition.

P Key: Key used to advance to successive parameters and parameter cycles.

▲ Increment Key and ▼ Decrement Key: Keys used to change parameter values.

⏪ Key: Key used to move back parameters during configuration.

5.1 STARTUP

When powered up, the controller displays its software version number for the first 3 seconds. After that, it will show the measured process variable (PV) value (temperature) in the upper display and the SP value in the lower display. This is the Indication Screen.

To be used in a process, you need to configure the controller. To configure it, you must define each of its parameters.

The configuration parameters are gathered into affinity groups, called parameter cycles:

Operation / Tuning / Timer / Alarms / Input / Calibration

The **P** key gives access to the cycles and their parameters.

By holding down the **P** key, the controller jumps from one cycle to another every 2 seconds, displaying the first parameter of each cycle:

PV >> RUN >> T1 >> FUR4 >> TYPE >> PRSS >> PV ...

To enter the desired cycle, simply release the **P** key when its first parameter is displayed. To advance through the parameters of this cycle, press the **P** key with short touches.

At the end of each cycle, the controller will return to the Indication Screen.

The symbol for each parameter will be shown in the upper display while its respective value/condition will be shown in the lower display.

6. PARAMETER DESCRIPTION

6.1 OPERATION CYCLE

PV + SP	PV Indication Screen. The value of the measured variable (PV) temperature is shown in the upper display (red). The control Setpoint value (SP) is shown in the lower display (green).
PV + TM	PV Indication screen and elapsed time. The upper display (red) shows the measured temperature value (PV). The lower display (green) shows the countdown of the time interval set for T1 Time. You cannot adjust this screen.
t1 Timer 1	Allows you to set the T1 Time interval. Adjustable between 00:00 and 99:59 (HH:MM or MM:SS). This parameter will be displayed in this cycle when defined in tEn parameter.
SP.A4	Alarm SP. Allows you to define the actuation point of the alarm outputs. For alarms programmed with Differential type functions, these parameters set deviations. This parameter will be displayed in this cycle when defined in SP4 parameter.
run Run	Allows you to enable or disable the controller's action on the process. It acts as a switch, turning the controller on or off. YES Enabled outputs. no Disabled outputs. This parameter will be displayed in this cycle when defined in runE parameter.

6.2 TUNING CYCLE

Autun Auto-tuning	AUTO-TUNING. Allows you to enable the automatic tuning of the PID parameters (Pb , Ir , dt). oFF Auto-tuning is off. FAST Perform tuning in Fast Mode. FULL Perform tuning in Accurate Mode. See SETTING THE PID PARAMETERS chapter.
Pb Proportional Band	Proportional Band. Value of the P term of the PID control mode. In percent of the maximum range of the input type. Adjustable between 0 and 500.0 %. When set to 0.0 (zero), it defines ON/OFF control mode.
Ir Integral Rate	Integral Rate. Value of the I term of the PID control mode. In repetitions per minute (Reset). Adjustable between 0 and 24.00. Displayed only if proportional band \neq 0.
dt Derivative Time	Derivative Time. Value of the D term of the PID control mode. In seconds. Adjustable between 0 and 250 seconds. Displayed only if proportional band \neq 0.
Ct Cycle Time	PWM Cycle Time. Value of the PWM Cycle period of the PID control. In seconds. Adjustable between 0.5 and 100.0 seconds. Displayed only if proportional band \neq 0.
HYS Hysteresis	Control hysteresis. Hysteresis value for ON/OFF control. Adjustable between 0 and the measurement range width of the selected input type. Displayed if proportional band $Pb = 0$.
Act Action	Allows you to set the control logic: rE Reverse Action control. Suitable for heating. Turns on the control output when PV is below SP. dir Direct Action control. Suitable for refrigeration. Turns on the control output when PV is above SP.
SFSt Soft Start	Soft Start Function. Allows you to set the time interval during which the controller will limit the control output (MV) rise speed. Adjustable between 0 and 9999 s. The value zero (0) disables the Soft Start function.
Out1 Out2 Out3 Out4	Allows you to set the operation mode of the OUT1, OUT2, OUT3, and OUT4 output channels: oFF Not used. Ctrl It acts as temperature control. A4 It acts as an Alarm 4 output. Lbd It acts as a LBD function output. t1 It acts as a T1 Timer output. t2 It acts as a T2 Timer output.

6.3 TIMER CYCLE

t1 <i>Timer 1</i>	Allows you to set the T1 Time interval. Adjustable between 00:00 and 99:59 (HH:MM or MM:SS).
tEn <i>Timer Enable</i>	Allows you to display the T1 Time parameter also in the Operation Cycle. YES Enables T1 to be displayed in the Operation Cycle. no DOES NOT enable T1 to be displayed in the Operation Cycle.
tDir	Allows you to set the timing direction of T1 : UP Progressive counting, starting from 0. dn Countdown.
tStr <i>Timer Start</i>	Allows you to set the T1 timer startup mode: di The DI starts and resets the timer. F  key starts, stops, and resets the timer. SP It starts when PV reaches SP. run It starts when you enable control (run = YES).
tEnd <i>Timer End</i>	Allows you to set the behavior of the T1 output at the end of T1 timer: off T1 output turns off at the end of T1 . on T1 output turns on at the end of T1 . onH T1 output remains on at the end of T1 .
tECo <i>Timer End Control Off</i>	Allows you to set the temperature control behavior at the end of the T1 + T2 timers. YES Finishes control at the end of the timer (run = no). no The temperature control continues to operate.
t2 <i>Timer 2</i>	Allows you to set the T2 Time interval. Adjustable between 00:00 and 99:59 (HH:MM or MM:SS). Time interval where the T2 output will remain on after the end of T1 timer.
tBAS <i>time base</i>	Allows you to set the time base for T1 and T2 timers. hh Hours and minutes (HH:MM). SEc Minutes and seconds (MM:SS).

6.4 ALARM CYCLE

FuA4 <i>Function Alarm</i>	Allows you to set the alarm functions according to the options in Table 2 .
SPA4	Alarm SP. Value that defines the actuation point of the alarm output. For Differential type functions, this parameter defines the deviations between PV and SP. This parameter is not used for the IErr alarm function.
SP4E	SP Enable. Allows you to display the SPA4 parameter in the Operation Cycle. YES Displays the SPA4 parameter in the Operation Cycle. no DOES NOT display the SPA4 parameter in the Operation Cycle.
bLA4 <i>Blocking Alarm</i>	Alarm 4. Initial Block. YES Enables the Initial Block. no DOES NOT enable the Initial Block.
HYA4 <i>Hysteresis of Alarm</i>	Alarm hysteresis. Allows you to set the difference between the PV value at which the alarm is turned on and the value at which it is turned off.
FLSh <i>Flash</i>	Allows you to indicate the occurrence of alarm conditions by flashing the PV indication on the indication screen. YES Enables the alarm signaling by PV flashing. no DOES NOT enable the alarm signaling by PV flashing.

6.5 INPUT CYCLE

TYPE Type	Allows you to define the input type to be used. J tc J -110 to 950 °C / -166 to 1742 °F K tc K -150 to 1370 °C / -238 to 2498 °F T tc t -160 to 400 °C / -256 to 752 °F Pt100 Pt -200 to 850 °C / -328 to 1562 °F
FLtr Filter	Input digital filter. Used to improve the stability of the measured signal (PV). Adjustable between 0 and 20. At 0, it means the filter is off. At 20, it means the filter is at maximum. The higher the filter value, the slower the response of the measured value.
dPPo Decimal Point	It determines the position of the decimal point on the display. When configuring the input (TYPE) with temperature sensors (J, K, Pt100, etc), in addition to the integer part of the measurement, the dPPo parameter will only display decimal values (XXX.X). When configuring the input (TYPE) with linear signals (mA, mV, V), the dPPo parameter determines the position of the decimal point of the measured value (XXXX, XXX.X, XX.XX, X.XXX).
unit Unit	Allows you to set the temperature unit to be used: °F Fahrenheit. °C Celsius.
OFFS Offset	Allows you to make corrections to the indicated PV value.
SPLL SP Low Limit	Allows you to set the lower limit to adjust SP.
SPHL SP High Limit	Allows you to set the upper limit to adjust SP.
Lbdt Loop break detection time	Time interval for the LBD function. Maximum time interval for the PV to react to control output commands. In minutes.
IEou	Percentage value to be applied to the output when occurs a failure in the sensor connected to the controller input.

6.6 CALIBRATION CYCLE

All input types are factory calibrated. When a recalibration is necessary, it must be performed by a specialized professional.

If you access this cycle by accident, do not change its parameters.

PASS Password	Password field. This parameter is displayed before the protected cycles. See CONFIGURATION PROTECTION chapter.
Calib Calibration	Allows you to enable the controller calibration. When not enabled, the corresponding parameters are hidden.
InLC Input Low Calibration	Declaration of the range start calibration signal applied to the analog input.
InHC Input High Calibration	Declaration of the range end calibration signal applied to the analog input.
rStr Restore	Allows you to restore the factory calibrations.
CJ Cold Junction	Cold junction temperature.
PASC Password Change	Allows you to set a new password, which must not be 0.
Prot Protection	Allows you to set the Protection Level. See Table 3 .
runE RUN Enable	Allows you to display the RUN (run) parameter also in the Operation Cycle: YES Displays RUN in the Operation Cycle. no DOES NOT display RUN in the Operation Cycle.
run Run	Allows you to enable or disable the controller's action on the process. It acts as a switch, turning the controller on or off. YES Enables outputs. no Disables outputs.

SnH Serial Number	It displays the last 4 digits of the electronic serial number of the controller.
SnL Serial Number	It displays the last 4 digits of the electronic serial number of the controller.

7. CONFIGURATION PROTECTION

The controller allows you to protect your configuration and prevent undue changes.

In the Calibration Cycle, the Protection parameter (**PrObt**) defines the protection level to be adopted, limiting access to the cycles, as shown in **Table 3**:

PROTECTION LEVEL	PROTECTED CYCLES
1	Only the Calibration cycle is protected.
2	The Input and Calibration cycles are protected.
3	The Alarm, Input, and Calibration cycles are protected.
4	The Timer, Alarm, Input, and Calibration cycles are protected.
5	The Tuning, Timer, Alarm, Input, and Calibration cycles are protected.
6	All cycles, except the SP screen in the Operation Cycle, are protected.
7	All cycles are protected.

Table 5 – Configuration Protection Levels

7.1 PASSWORD

When accessing the protected cycles, you will need to enter the password to be able to change they configuration.

You must enter the password in the **PR55** parameter, the first parameter of the protected cycles. Without it, the parameters of the protected cycles can only be viewed.

The password is set in the **Password Change** parameter (**PR5L**), presented in the Calibration Cycle.

The controller is supplied with the Access Password set to 1111.

7.2 PASSWORD PROTECTION

The controller has a safety system. It helps prevent the input of several passwords in an attempt to get the correct password right.

Once 5 consecutive invalid passwords are identified, the controller will stop accepting passwords for 10 minutes.

7.3 MASTER PASSWORD

If you forget your password, you can use the Master Password feature. When inserted, this password allows you to change the **Password Change** parameter (**PR5L**) and set a new password for the controller.

The master password is composed of the last three digits of the controller's serial number **plus** the number 9000.

For a device with serial number 07154321, for example, the master password is 9 3 2 1.

You can obtain the serial number of the controller by pressing  for 5 seconds.

8. SETTING THE PID PARAMETERS

During automatic tuning, the process is controlled in **ON/OFF** mode at the programmed Setpoint (SP).

In some processes, automatic tuning can take many minutes to complete.

The recommended procedure for running it is:

- Set the desired SP value for the process.
- In the **Atun** screen, enable automatic tuning by selecting between **FAST** or **FULL** options.

The **FAST** option performs the tuning in the shortest possible time. The **FULL** option prioritizes more precise tuning.

During automatic tuning, the TUNE flag will remain lit on the front of the controller. You must wait until the tuning process is finished before you can use the controller.

During the Auto-tuning, PV oscillations can be induced in the process around the Setpoint.

If the tuning does not result in satisfactory control, **Table 5** gives guidelines for correcting the process behavior:

PARAMETER	PROBLEM DISCOVERED	SOLUTION
Proportional Band	Slow response	Decrease
	Great oscillation	Increase
Integration Rate	Slow response	Increase
	Great oscillation	Decrease
Derivative Time	Slow response or instability	Decrease
	Great oscillation	Increase

Table 6 – Manual adjustment of the PID parameters

9. MAINTENANCE

9.1 PROBLEMS WITH THE CONTROLLER

Connection errors and improper programming are the most common errors during controller operation. A final review can avoid wasted time and damage.

The controller displays some messages that are intended to help you identify problems:

MESSAGE	PROBLEM DESCRIPTION
----	Open Input. No sensor or signal.
Err 1 Err 6	Connection and/or configuration problems. Review the connections and the configuration.







Table 7 – Error messages

Other error messages shown by the controller represent internal damage that necessarily implies sending the equipment for maintenance.

9.2 INPUT CALIBRATION

All controller input types leave the factory already calibrated, and recalibration is not recommended for inexperienced operators.

If you need to recalibrate an input, proceed as described below:

- a) In the **TYPE** parameter, set the input type to be calibrated.
- b) Configure the lower and upper SP limits for the maximum span of the input type.
- c) Access the Calibration Cycle.
- d) Enter the password.
- e) Enable the calibration when setting the parameter **CAL Ib** to **YES**.
- f) Using an electrical signal simulator, apply to the input terminals a signal level close to the lower limit of the configured input range.
- g) In the **InLC** parameter, use the  and  keys to adjust the display reading such as to match the applied signal. Then press .
- h) Apply a signal near the upper limit of the configured input's measurement range to the input terminals.
- i) In the **InHC** parameter, use the  and  keys to adjust the display reading such as to match the applied signal. Then press  until you return to the PV Indication Screen.
- j) Confirm the calibration done.

Note: When checking the controller, make sure that the Pt100 excitation current required by the calibrator used is compatible with the Pt100 excitation current used in this instrument: 0.170 mA.

10. SPECIFICATIONS

DIMENSIONS: 48 x 48 x 80 mm (1/16 DIN)
Panel cut-out: 45.5 x 45.5 mm (+0.5 -0.0 mm)
Approximated weight: 75 g

POWER SUPPLY:

..... 100 to 240 Vac (50/60 Hz) / 48 to 240 Vcc / $\pm 10\%$
Optional 24 V 12 to 24 Vdc / 24 Vac (-10 % / +20 %)
Maximum consumption: 6 VA

ENVIRONMENTAL CONDITIONS:

Operating temperature: 0 to 50 °C
Relative humidity: 80 % @ 30 °C
(For temperatures above 30 °C (86 °F), reduce by 3 % for each °C)
Installation category II, Installation degree 2; Altitude < 2000 m

INPUT:

Accepted types: J, K, T, Pt100
Internal resolution: 32767 levels (15 bits)
Display resolution: 0.1 / 1 (°C / °F)
Input reading rate: up to 10 per second (*).
Accuracy: J, K, T Thermocouples: 0.25 % of the span ± 0.1 °C
..... Pt100: 0.2 % of the span ± 0.1 °C
Input impedance: 4.5 m Ω
Pt100 measurement: 3-wire type, ($\alpha=0.00385$)
With cable length compensation, excitation current of 0.170 mA.

(*) Value adopted when the Digital Filter parameter is set to 0. For Digital Filter values other than 0, the Input Reading Rate value is 5 samples per second.

DIGITAL INPUT (DIG IN) Dry contact / NPN collector-open

OUTPUT 1: Voltage pulse, 5 V / 50 mA max.

OUTPUT 2: SPST Relay; 1.5 A / 240 Vac / 30 Vdc

OUTPUT 3: SPST Relay; 1.5 A / 240 Vac / 30 Vdc

OUTPUT 4: SPDT Relay / 3 A / 240 Vac / 30 Vdc

FRONT PANEL: IP65, Polycarbonate (PC) UL94 V-2

HOUSING: IP30, ABS+PC UL94 V-0

CONNECTIONS SUITABLE FOR PIN TYPE TERMINALS.

PROGRAMMABLE PWM CYCLE FROM 0.5 TO 100 SECONDS.

IT STARTS OPERATION 3 SECONDS AFTER BEING CONNECTED TO THE POWER SUPPLY.

CERTIFICATIONS:



11. IDENTIFICATION

N1040T-PRRR	Standard model. Power Supply 100~240 Vac / 48~240 Vdc
N1040T-PRRR-24V	Model with power supply 12~24 Vdc / 24 Vac

12. WARRANTY

Warranty conditions are available on our website www.novusautomation.com/warranty.